

## Installation Instructions

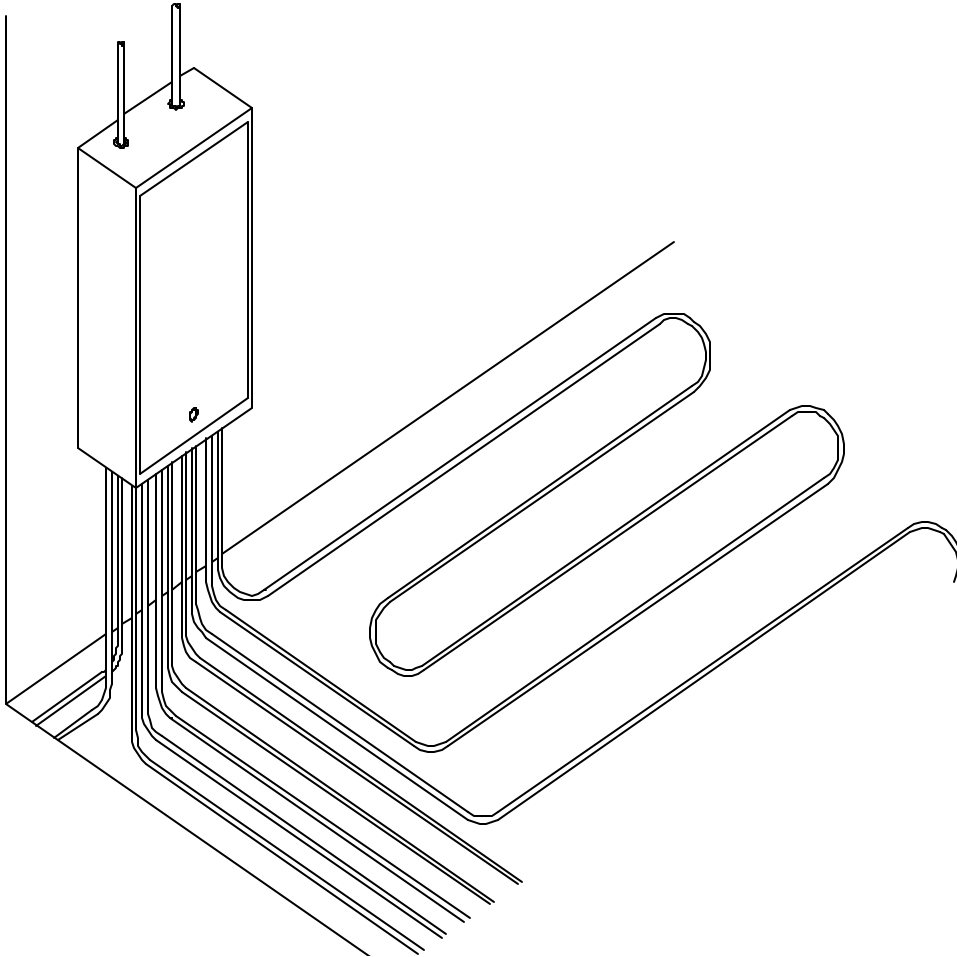

### *Introduction*

TMM™ (Thermostatic Mixing Module) is a self-contained package for radiant floor heating. It can provide floor warming or room heating for an entire building or anywhere that requires extra comfort through radiant floor heating. It is suitable for new construction or for renovations – commercial, industrial, agricultural or residential.

Designed specifically to be connected directly to a tankless water heater, the TMMD™ has a primary pump, floor pump, temperature control valve and electronic controls, all contained in an attractive cabinet. It can be mounted anywhere and in any orientation: up, down or horizontally. The unit comes pre-assembled to save time and simplify installation.

### Physical Properties

Model	Cabinet dimensions			Water Connections*		Shipping Weight
	height	width	depth	Heat source	Radiant loops	
TMMD40-I	24"	14"	8"	1/2"	1/2"	25 lb.
TMMD70-I	24"	14"	8"	3/4"	3/4"	40 lb.
TMMD70-II	24"	14"	8"	3/4"	3/4"	50 lb.
TMMD70-III	30"	22"	8"	3/4"	3/4"	58 lb.

Sweat connections are standard. \*

## ***Mounting***

The TMMD™ may be mounted in a mechanical room or basement wall or in a closet. It may be surface mounted or recessed into the wall. It may be mounted in any orientation: up, down or horizontally.

For **surface mounting**, use anchors suitable for the wall surface (concrete, drywall or wood screws). The cabinet should be screwed through the top and bottom flanges.

For **recessed installations**, the cabinet may be screwed from the inside through the sides of the cabinet into the wall stud. The cabinet is designed to fit between wall studs that are 16 or 24 inches on centre. Additional wood blocking may be necessary to support both sides of the cabinet. It is recommended that the TMMD™ be recessed at least 3-1/2" in order to hide all plumbing connections. Note: for recessed installations, all plumbing connections must be completed before the drywall is installed around the cabinet.

## ***Piping Layout***

Poly Ethylene Cross-linked tubing (PEX) is used in the radiant floor panel. The PEX tubing is connected to supply and return manifolds that are fed from the floor pump of the TMMD™. The supply **OR** return manifold **MUST** have circuit isolation valves (12) on each loop of the radiant floor panel. This is to ensure that the positive purging of air from the panel can be performed. See **Start-up**.

## ***Plumbing Connections***

All connections to the TMMD™ are sweat or optional male NPT. PEX with an oxygen barrier

is not required for open (water heater) systems, iron-free boiler systems or boiler systems isolated with a heat exchanger. Many options are available for circuiting the in-floor loop layout including remote manifolds.

Connect 3/4" supply and return pipes to the tank-less water heater and to the connections on the TMMD™ as shown in the diagram and labeled inside the cabinet.

## ***Electrical Connections***

Plug the electrical cord into a standard 120VAC/60Hz/1Ph grounded outlet. This device draws less than 3 amps and does not need to be on a separate circuit. The cord can be removed and the unit hard wired by a qualified electrician. Follow all local electrical codes.

Connect low voltage thermostat wire from the red and white wires (R & W) of the TMMD™ control to the thermostat. The TMMD™ includes a pre-wired 24VAC power supply for the controls.

## ***Start up***

Ensure all plumbing connections are complete.

Purge all air from the plumbing or hydronic system. To purge air from the radiant heating system, open both heat source isolation valves. Connect a drain hose to the return leg purge valve. Open the purge valve. Once the water starts flowing through the drain hose, close the return isolation valve. Close all but one of the individual isolation valves on the supply or return manifold taking turns to purge all of the air out of each of the circuits (loops).

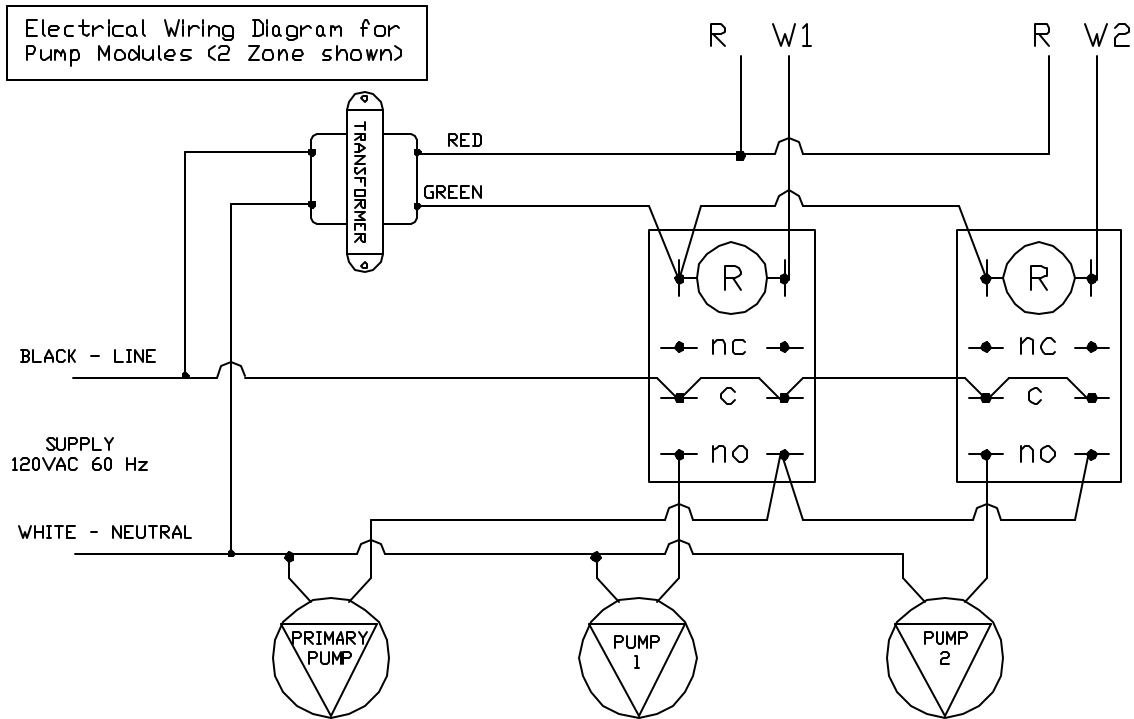

When all of the individual circuits have been positively purged, close the purge (drain) valve and open the return isolation valve. Remove the drain hose.

Once the TMMD™ has been positively purged, plug in the TMMD™ and set the room thermostat at the desired setting. The tankless water heater will fire when it senses the flow from the TMMD™.

Set the mixing valve to the desired temperature. Refer to the following table and the mix valve instructions.

	Loop Temp.	Mix Valve Setting	
		w.h. (140F)	Boiler (180F)
<b>Floor warming (15 Btu/hr./sq.ft.)*</b>			
in-slab with vinyl or ceramic floor	88	5	3
in-slab with carpeting	103	9	7
In-joist with vinyl or ceramic floor	103	9	7
In-joist with carpeting	118	13	11
<b>Space Heating (30 Btu/hr./sq.ft.)*</b>			
in-slab with vinyl or ceramic floor	108	11	9
in-slab with carpeting	138	23	17
In-joist with vinyl or ceramic floor	138	23	17
In-joist with carpeting	168	Not rec.	21

\* These are guidelines only. Temperature adjustments may be required. For space heating, a proper heat loss is required. Contact Ecologix for assistance

TMMD40-I  
TMMD70-I

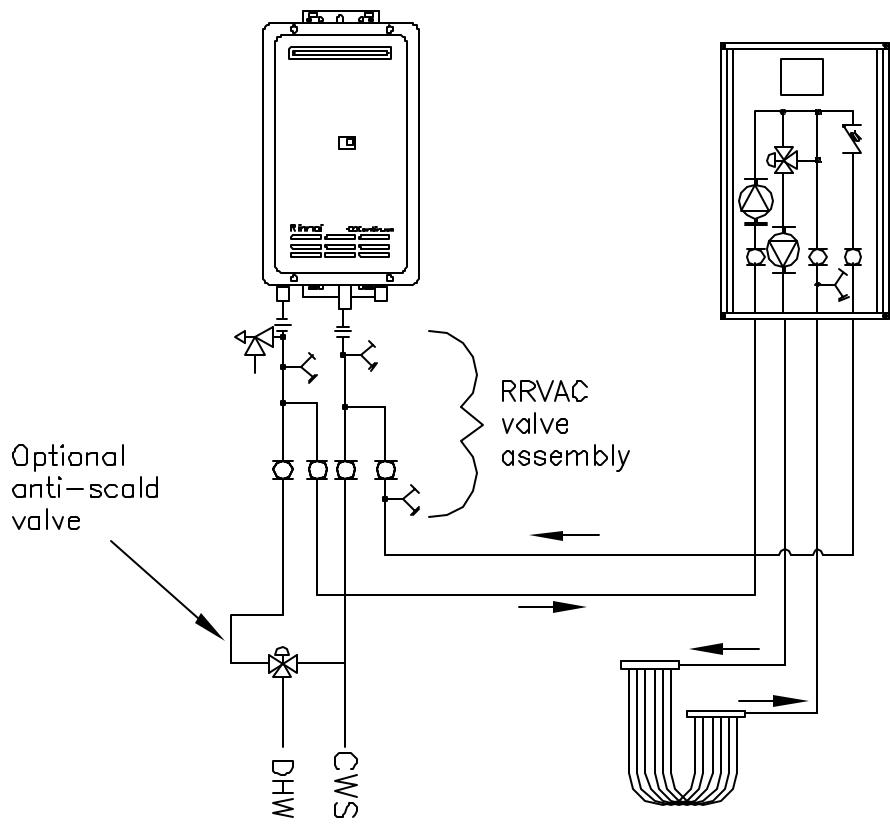

TMMD70-II  
TMMD70-III

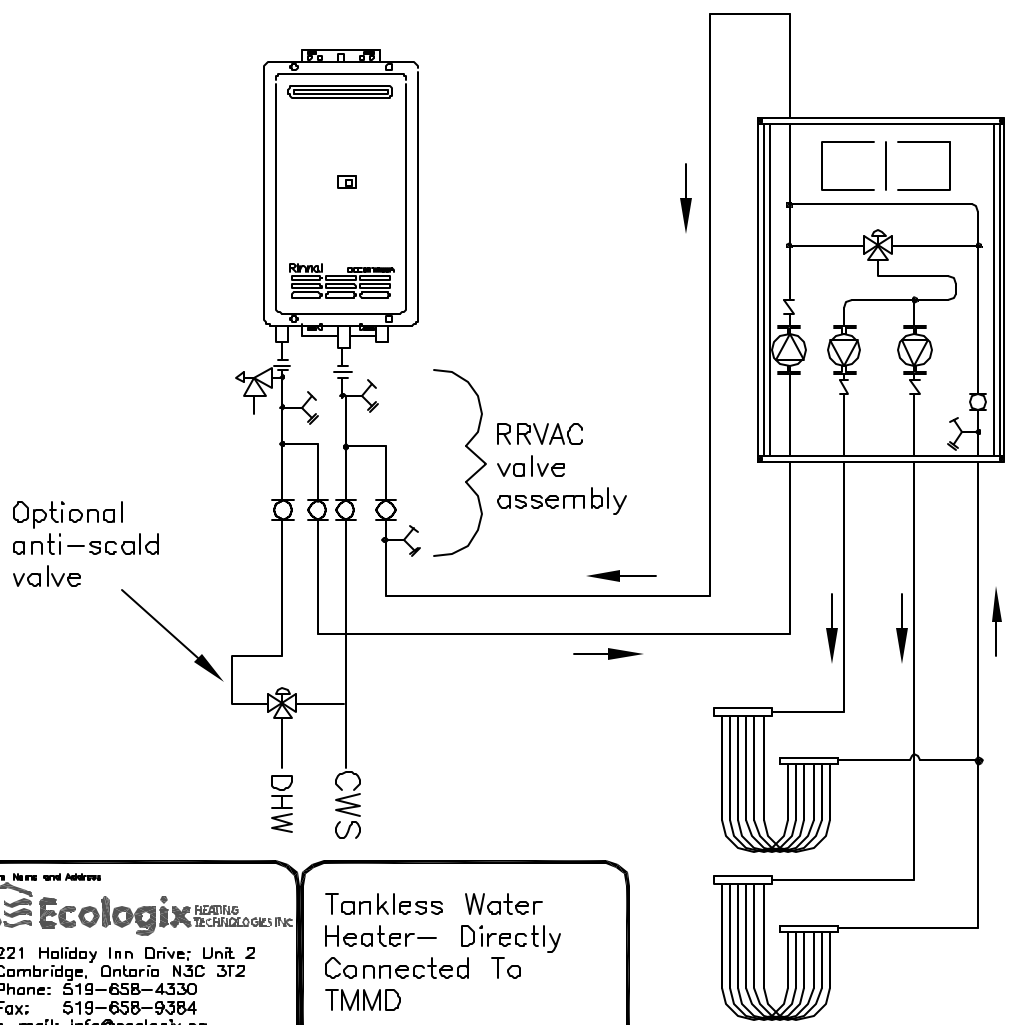

**Ecologix** HEATING TECHNOLOGIES INC.  
 221 Holiday Inn Drive, Unit 2  
 Cambridge, Ontario N3C 3T2  
 Phone: 519-658-4330  
 Fax: 519-658-9384  
 e-mail: info@ecologix.ca

Tankless Water  
 Heater— Directly  
 Connected To  
 TMMD

Drawing Number  
 \_\_\_\_\_  
 Revision  
 \_\_\_\_\_