

---

# Installation Instructions

---

**eco-pac & eco-duct EC**  
hot water air handler  
with high efficiency EC motor

**ECOLOGIX HEATING TECHNOLOGIES INC.**

221 Holiday Inn Dr.  
Cambridge, Ontario  
N3C 3T2

Phone: 519-658-4330  
Fax: 519-658-9384  
info@ecologix.ca  
www.ecologix.ca

# **Table of Contents**

<b>IMPORTANT NOTES FOR THE INSTALLER .....</b>	<b>3</b>
<b>TYPICAL PLUMBING CONNECTIONS .....</b>	<b>4</b>
<b>ELECTRICAL WIRING DIAGRAM.....</b>	<b>5</b>
<b>INTRODUCTION.....</b>	<b>8</b>
<b>HOW IT WORKS .....</b>	<b>9</b>
COOLING .....	9
HEATING .....	9
CONTINUOUS FAN.....	9
<b>PRODUCT DESCRIPTION .....</b>	<b>10</b>
CABINET .....	10
HEATING COILS .....	10
FAN AND MOTOR .....	10
CIRCULATING PUMP .....	10
CHECK VALVE .....	10
CONNECTING TO A WATER HEATER .....	11
CONNECTING TO A BOILER.....	11
<b>EQUIPMENT SELECTION AND SIZING .....</b>	<b>11</b>
HEAT LOSS .....	11
AIR HANDLER SELECTION.....	11
DUCT LAYOUT .....	12
<b>INSTALLATION.....</b>	<b>13</b>
AIR HANDLER MOUNTING .....	13
DUCTWORK .....	13
RISK OF FREEZING .....	14
<b>ELECTRICAL .....</b>	<b>14</b>
THERMOSTAT .....	14
A/C CONDENSING UNIT .....	15
<b>START-UP PROCEDURES .....</b>	<b>16</b>
<b>SERVICE AND MAINTENANCE .....</b>	<b>17</b>
<b>TROUBLESHOOTING.....</b>	<b>18</b>
THERMOSTAT CALL ERROR .....	18
PUMP DOES NOT RUN .....	18
PUMP IS NOISY AT START-UP .....	18
WATER HEATER T&P IS WEEPING.....	18
INSUFFICIENT OR NO HEAT .....	18
COLD WATER AT HOT FAUCET .....	19
FAN RUNS FOR COOLING BUT NOT HEATING.....	19
HEATING DURING STANDBY MODE .....	19
<b>eco-pac/eco-duct AIR HANDLER PARTS &amp; ACCESSORY LIST .....</b>	<b>20</b>
<b>PRODUCT WARRANTY .....</b>	<b>21</b>

## **IMPORTANT NOTES FOR THE INSTALLER**

<input checked="" type="checkbox"/>	<b>A Quick Check List</b>
<input type="checkbox"/>	Are the water connections to the water heater oriented in a way to avoid trapping air in the heating circuit? (see diagram on next page)
<input type="checkbox"/>	Is the purge valve installed on the return line from the air handler upstream from the isolation valve?
<input type="checkbox"/>	Is the air handler hung and isolated to avoid transmitting vibration through framing and duct work?
<input type="checkbox"/>	Are the isolation valves full-port? Restrictive valves will limit performance.
<input type="checkbox"/>	Are Thermostat connections correct, including cooling and continuous run connections?
<input type="checkbox"/>	Have the packing materials been removed from the blower and the pump ?
<input type="checkbox"/>	Is there an installation manual for the home owner ?
<input type="checkbox"/>	Is the unit accessible? Are there clearances for service and component replacement?
<input type="checkbox"/>	Are the supply plenum and return duct/drop acoustically lined ? (at least 6' of the return duct/drop must be lined in addition to the supply plenum)
<input type="checkbox"/>	Is the filter cover in place? Is a clean filter in place? Is the supplied filter rack installed?



# TYPICAL PLUMBING CONNECTIONS

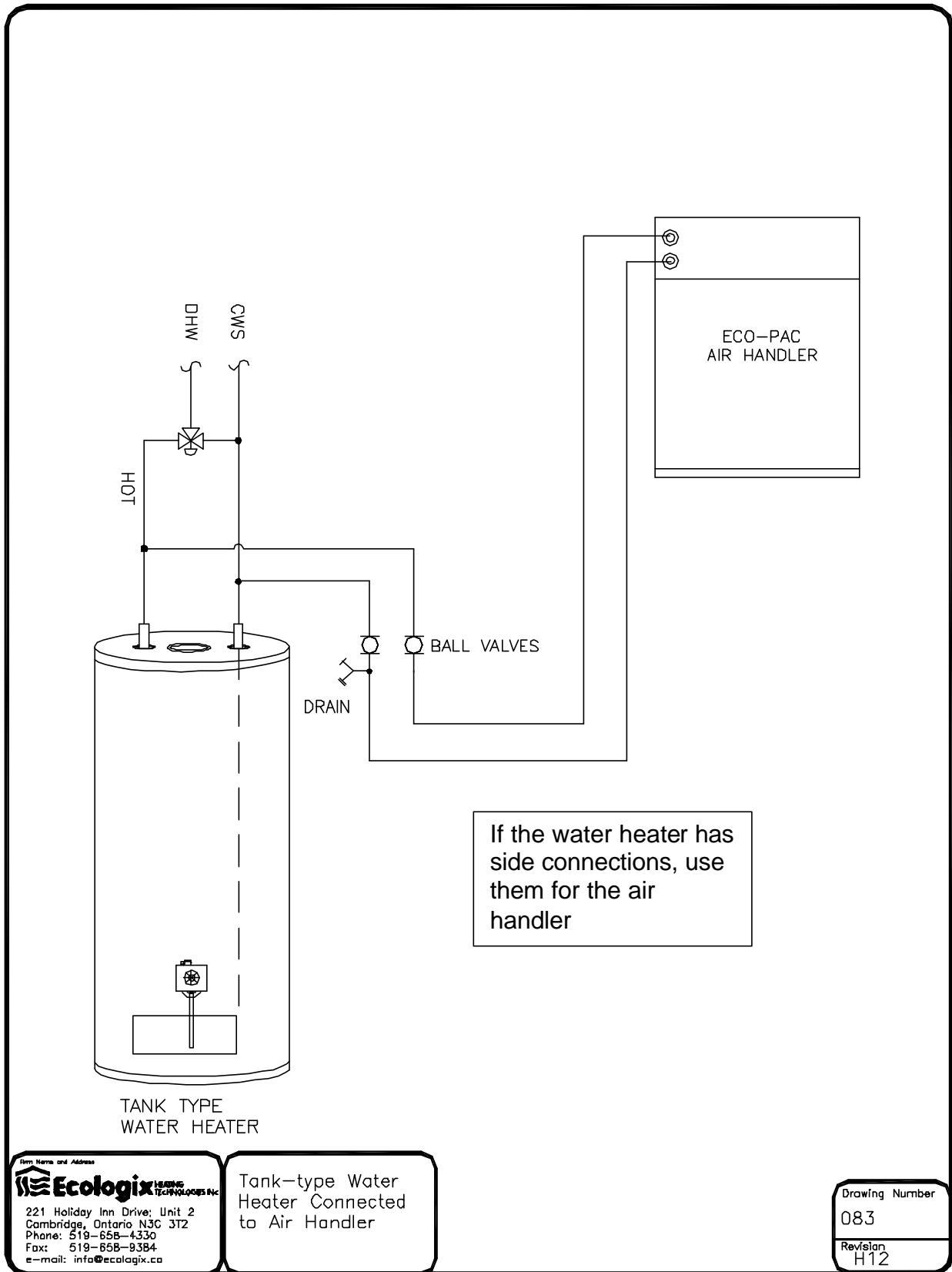



**Ecologix** HEATING & TECHNOLOGIES INC.  
 221 Holiday Inn Drive, Unit 2  
 Cambridge, Ontario N3C 3T2  
 Phone: 519-658-4330  
 Fax: 519-658-9384  
 e-mail: info@ecologix.ca

Tank-type Water Heater Connected to Air Handler

Drawing Number  
 083  
 Revision  
 H12

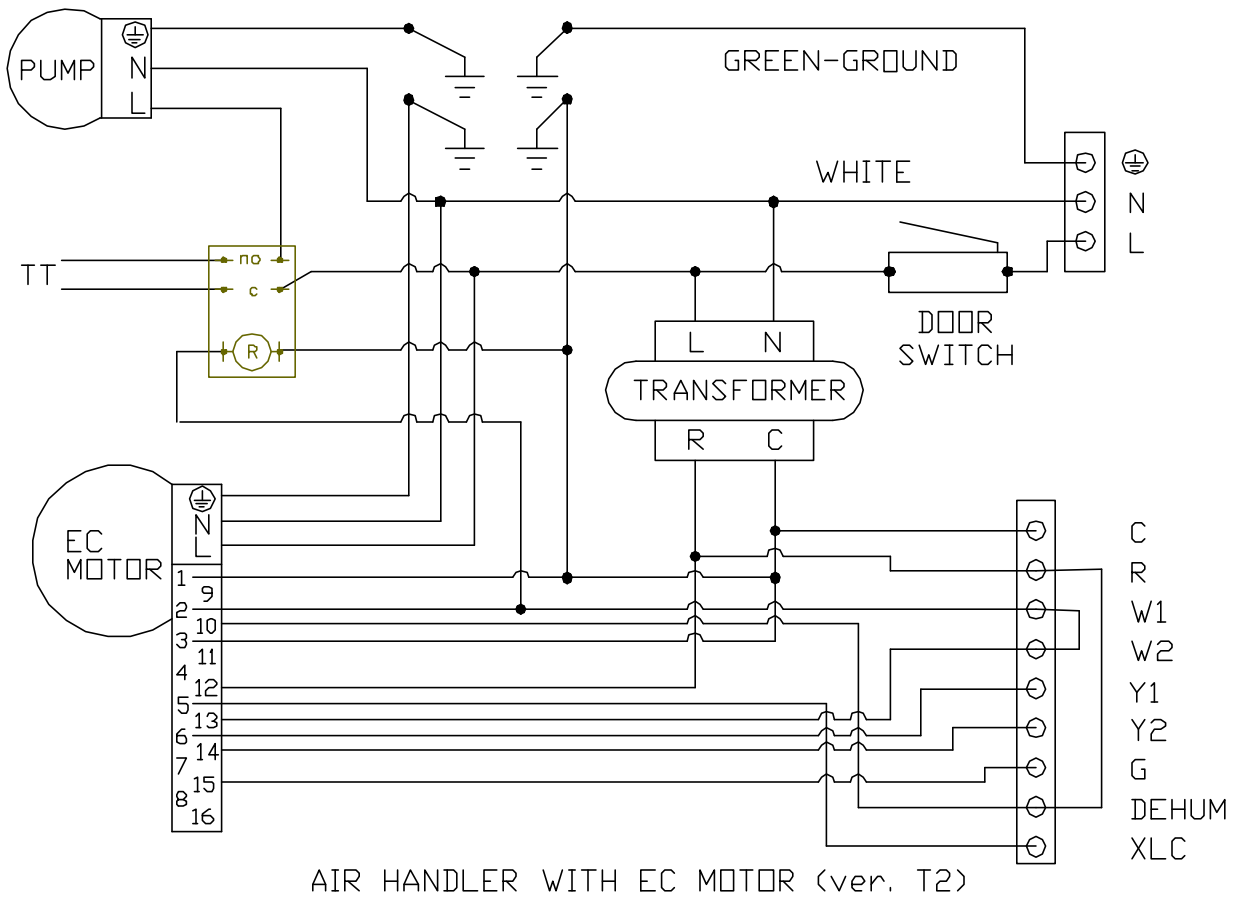
# ELECTRICAL WIRING DIAGRAM



EC Motor Control Wires		
Wire Number	Typical Colour	Function
1	Green/Yel.	C1 Ground
2	White/stripe	W1 (Low Heating Speed)
3	Green/Yel.	C2 Ground
4	N/A	
5	Black/stripe	XLC (EP60-EC)
6	Yellow	Y1 (Low Cooling Speed)
7	N/A	
8	N/A	
9	N/A	
10	Blue	DEHUM (OFF for dehumidification)
11	N/A	
12	Red	R (24VAC Power)
13	White	W2 (High Heating Speed)
14	Violet	Y2 (Medium Cooling Speed)
15	Brown	G (Continuous Fan Speed)
16	N/A	

## Physical Properties

Model Type	Cabinet dimensions			Supply air	Return air	water inlet and outlet	Shipping Weight
	A depth	B width	C height	d x e	f x g		
EP30, EDHV-12, EDHV-18	20"	14"	24"	12"x16"	12"x16"	1/2"	80 lb.
EP45 to EP75, EDHV-24 to EDHV-60	22"	22"	31.5"	20"x20"	20"x20"	3/4"	110 lb.
EP100, EDHV-100	22"	22"	48"	20"x20"	20"x20"	3/4"	120 lb.

## Unit Specifications: eco-pac EC™ air handlers

MODEL:	EP30-EC	EP45-EC	EP60-EC	EP65-EC	EP75-EC	EP100-EC
*Heating Capacity (Btu/h) 120F water	21,000	32,000	43,000	47,000	55,000	76,000
*Heating Capacity (Btu/h) 130F water	28,000	42,000	56,000	61,000	71,000	91,000
*Heating Capacity (Btu/h) 140F water	30,000	45,000	60,000	66,000	77,000	106,000
*Heating Capacity (Btu/h) 160F water	37,000	57,000	77,000	85,000	100,000	135,000
*Heating Capacity (Btu/h) 180F water	48,000	72,000	95,000	104,000	122,000	164,000
(USGPM) Heating	2.3	4.5	4.5	4.5	4.5	7.0
Maximum Heating Airflow (CFM)	800	900	1200	1400	2000	2000
Max. External Static Pressure ("wc)**	1.2	1.3	0.5	1.0	0.5	1.0
Cooling Capacity – High (Tons)	2.0	3.0	3.0	3.5	5.0	5.0
Cooling Capacity – Medium (Tons)	1.5	3.0	3.0	3.0	4.0	4.0
Cooling Capacity – Low (Tons)	1.0	2.5	2.5	2.5	3.5	3.5
Cooling Capacity						3.0
Cooling Capacity – Low2 (Tons)	--	2.0	2.0	2.0	--	2.5
Cooling Capacity – Low3 (Tons)	--	1.5	1.5	1.5	--	2.0
Blower Motor Full Load (Amps)	5.5	5.5	5.5	7.7	9.6	9.6
Circulator Full Load (Amps)	0.6	0.8	0.8	0.8	0.8	0.8

\*based on 70F return air, high fan speed and 20F water temperature drop through the coil.

Contact Ecologix for performance at lower water temperatures.

\*\* air handler can deliver maximum programmed airflow at any static pressure below this value.

## Unit Specifications: Eco-Duct™ air handlers

MODEL	EDHV-12	EDHV-18	EDHV-24	EDHV-30	EDHV-36	EDHV-42	EDHV-48	EDHV-60	EDHV-100
Number of 3" outlets <sup>1</sup>	8	12	15	18	22	26	30	36	40
Cooling Capacity (Tons)	1.0	1.5	2.0	2.5	3.0	3.5	4.0	5.0	5.0
*Heating Capacity (MBH) 130F water	15	21	35	41	46	49	52	57	91
*Heating Capacity (MBH) 140F water	18	25	41	48	54	57	61	67	106
*Heating Capacity (MBH) 160F water	24	33	53	62	69	74	78	86	135
*Heating Capacity (MBH) 180F water	30	40	65	76	85	91	96	105	164
(USGPM) Heating	2.3	2.3	4.5	4.5	4.5	4.5	4.5	4.5	7.0
Nominal Airflow (CFM) <sup>2</sup>	360	540	720	900	1080	1260	1440	1800	2000
Blower Motor Full Load (Amps)	5.5	5.5	5.5	5.5	7.7	7.7	9.6	9.6	9.6
Circulator Full Load (Amps)	0.8	0.8	0.8	0.8	0.8	0.8	0.8	0.8	0.8

1. Minimum Required. Refer to Design and Installation Instructions for options.

2. All air flows at maximum speed.

\*based on 70F return air, high fan speed and 20F water temperature drop through the coil. Contact Ecologix for performance at lower water temperatures.

## INTRODUCTION

---

**eco-pac/eco-duct™** air handlers are designed for use with hydronic (boiler) systems or in combination space and water heating systems (Combo Systems). Combo heating systems use the home's water heater to provide both the space heating and domestic hot water, eliminating the need for a furnace.

Combo heating systems are ideally suited for single-family homes, townhouses and apartments where the cost of a furnace does not make sense or space requirements are limited. They are also great for additions, renovation and finished basements as a replacement for, or in addition to the existing heating system. Ecologix air handlers are also great for hydronic heating systems using ground-source heat pumps. They are the smallest units available in their capacity range.

**eco-pac/eco-duct™** air handlers are designed to take the guesswork out of system sizing and installation. Matched

specifically to common water heater sizes, Ecologix air handlers can be quickly sized using the quick sizing information in our spec sheets or from air handler performance curves. For applications requiring special consideration, call 519-658-4330 for answers to questions related to sizing, installation or trouble-shooting for any of Ecologix air handlers or water heaters.

Ecologix provides you with the quietest operating air handler available. By using large capacity, high output heating coils, these air handlers deliver more heating per volume of air, which means warmer delivered air temperatures.

**eco-pac™** air handlers are intended for conventional duct systems and **eco-duct™** air handlers are intended for **small-D™** duct systems with higher operating static pressure. Refer to the **small-D™** design manual for more details on duct design and installation.

## HOW IT WORKS

---

The key to the **eco-pac/eco-duct™** system is the level of comfort provided by the unique control system.

### **Cooling**

In a typical installation, a call for cooling will bring on the air handler. The fan will slowly ramp up (15 seconds) to speed and continue until the call is satisfied.

#### **Dehumidification:**

If an optional dehumidifier is installed in the home, it can be interlocked to the air handler. When installed, the air handler will run at a lower speed to increase the dehumidification during a cooling call. Refer to the wiring diagram for connection details.

#### **Cooling Fan Speed Selection:**

The installer can select one of several (3 or 6) speeds that the air handler will operate at during cooling mode.

### **Heating**

1) When a heating call is initiated, the air handler will start at a very low speed. This will continue for a maximum of 45 seconds, allowing the water coil to be pre-heated with hot water.

2) After this initial phase, the air handler will ramp up to a medium speed and remain there for 15 minutes. During most of the heating season, this will be enough to satisfy the call. If the call for heat terminates during this phase, the air handler will shut off. Times where the

load is higher, the air handler will continue on into the final phase.

3) The final phase of heating operation is full capacity; this will provide the maximum amount of heating to the space. Once the thermostat satisfies, the air handler will slow down and shut off within 15 seconds.

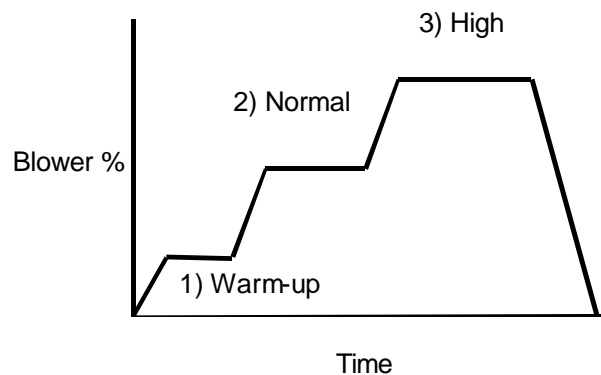

### **Continuous Fan**

When the thermostat fan switch is set to continuous fan, the fan will run at low speed (50% of maximum). When there is a call for heating or cooling, the normal heating or cooling speed will over-ride the continuous fan setting. Once the thermostat is satisfied, continuous fan speed will resume.

## PRODUCT DESCRIPTION

---

Ecologix air handlers are certified by:  
Entela Inc.  
81 Kelfield St., Unit 7  
Toronto, Ontario  
M9W 5A3  
Ph: 416-241-8427  
Fx: 416-241-0682

Ecologix air handlers are in conformity with the following standards:

CAN CSA-22.2 No. 236M95

UL 1995 2<sup>nd</sup> Ed.

As shown in certification report number: 0301154695, File number 8502, dated: 01/27/03

### ***Cabinet***

All cabinets have a tough, durable low maintenance pre-painted finish.

Cabinet dimensions are designed to provide maximum installation flexibility. Refer to installation requirements for more details.

### ***Heating Coils***

All heating coils are potable water grade copper suitable for use in plumbing systems. No lead solder is used in any component construction. All coils and internal piping conform to ASTM B68 or ASTM B88 standards.

High-density aluminum fins provide maximum heat transfer for small coil surface.

### ***Fan and Motor***

All fans are wide body dynamically balanced for extra quiet operation.

Multi-directional sleeve bearing motors allow mounting in any direction for maximum installation flexibility.

### ***Circulating Pump***

The circulating pump is matched for maximum performance. Air handlers come with internally mounted pumps for ease of installation. Air handlers can be special ordered with external, field installed pumps, when it is desirable to locate the circulator below the air handler, such as in attic installations.

### ***Check Valve***

Check valves serve two purposes:

- protect against back-flow of water to avoid short circuiting around the water heater during domestic water use.
- protect against thermal siphoning.

Thermal siphoning is flow of water through the space heating circuit while the circulating pump is not operating due to hot water rising by natural convection. During summer months this will cause

overheating, interfere with air conditioning and waste energy.

All **Ecologix** air systems come supplied with spring loaded, vertical lift check valves. These check-valves have been tested and proven to resist thermal siphoning for installations where the air handler elevation does not exceed the distance above the water heater shown in the table below.

#### Check Valves

valve size	Maximum elevation
1/2"(12mm)	25 feet(8 metres)
3/4"(20mm)	50 feet(15 metres)

#### **Connecting to a Water Heater**

Any properly sized gas, propane or oil fired water heater will work in a combo heating system. Make sure the water heater being used is approved for combo applications. (Most manufacturers' heaters are approved.) Tank-less water heaters may reduce the capacity of air handlers due to the higher internal pressure drop. (Call Ecologix for details)

#### **Connecting to a Boiler**

All **Ecologix** air systems are compatible for use with boilers. Standard drawings are available from Ecologix for most boiler applications.

## EQUIPMENT SELECTION AND SIZING

---

Proper sizing of system components is crucial for proper operation.

Steps for sizing and selection:

- 1) Obtain room by room heat loss and/or heat gain
- 2) Determine heating water temperature
- 3) Select air handler from specification sheet
- 5) Determine duct layout

#### **Heat Loss**

Make sure a proper room-by-room heat loss and heat gain for the dwelling is calculated using HRAI, ASHRAE or other approved sizing method.

#### **Air Handler Selection**

Select the desired air system that will meet 100%-140% of the heating load and 80%-120% of the cooling load.

If using a boiler system, select a boiler that has an output that meets or exceeds the heat loss of the space being heated. If the boiler is meeting additional loads, size the boiler to meet the total combined load.

For combo heating systems, use an approved sizing method such as the Unified Combo Guidelines published by HRAI. In areas where the UCG or a local sizing code is not applicable, use the

following method for sizing combo systems:

- 1) Select an air handler that meets or exceeds the calculated heat loss at the water heater operating temperature (130F/55C or 140F/60C).
- 2) Select a water heater with an output that is at least 120% of the heat loss

### ***Duct Layout***

Make sure a proper duct design has been completed for the dwelling using HRAI, ASHRAE or other approved design method.

#### Supply air Plenum

Provide an acoustically insulated supply air plenum that is the same dimensions as the outlet flanges of the air handler. A length of 36 inches is recommended.

A smooth, square-to-round transition may be used in place of the supply air plenum for horizontal installations where there is only one supply main.

For vertical applications where the air conditioning coil is installed in the supply air plenum, the cooling coil must be supported at least 4 inches above the heating coil face on brackets or channel to ensure unimpeded airflow through the heating coil.

Plenum takeoffs may be mounted on the end of the plenum or the sides of the plenum, but not both. Spin-in collars or transition takeoffs may be used, but not both.

#### Supply mains

Plan duct layout to avoid branch runs in outside walls or attics and to minimize the length of the main duct

Where practical, provide parallel main ducts to various floors or zones rather than running a single larger duct with tees. For applications with 3 or more floors or any application where a large seasonal adjustment in airflow is anticipated, parallel main supply ducts must be used. Volume dampers in each of the main supply ducts must be installed and must be accessible for seasonal adjustments. For example; a 4-storey townhouse will probably require vastly different airflow rates for the upper floors between cooling and heating seasons. If there are two main supply trunks, the supply trunk serving the upper 2 floors can be damped down in the heating season to better balance the air flows.

Supply mains may be round duct or equivalent rectangular duct.

Round duct can be spiral duct, welded or snap lock seams.

Rectangular duct must be at least 26 gauge for all dimensions. The aspect ratio for square ducts (wide dimension over short dimension) shall not exceed 2.5 to1.

#### Return air duct

The return air duct or drop must be acoustically insulated for at least 6 feet nearest the air handler. The return air duct should be sized for a total pressure drop of not more than 0.15" w.c. Using conventional sizing methods and installed in accordance with HRAI guidelines or equal.

Refer to the **small-D™** design guide for additional requirements for small

diameter/higher static duct applications.

## INSTALLATION

---

The installer must adhere strictly to all local and national code requirements pertaining to the installation of this equipment.

Detailed instructions are shipped with all accessory items and should be followed in detail.

### ***Air Handler Mounting***

The **Ecologix** air handler can be installed in any direction. Its compact dimensions even allows for installation between joists. The air handler can be floor mounted or hung from straps. Some precautions must be observed for some of the possible mounting positions.

For installations where the access door faces up or down, select an air handler with an external pump to avoid the pump being mounted with its shaft vertical. The pump shaft must be mounted horizontally to avoid premature failure.

The air handler can be hung by securing straps through any of the existing screw holes in the cabinet. When the existing screw is too short for securing a mounting strap, a longer screw can be used provided care is taken not to damage any internal components. When fastening straps using screws other than those supplied with the cabinet, special care should be taken in the vicinity of the coil to avoid tube puncture.

**Warning!: Do not put screws into the cabinet directly in front of and behind the coil.**

3/4" screws can be safely installed on either side of the coil.

The cabinet is designed so that the return air can be located on either side of the cabinet, through the bottom of the cabinet, or from the back. Position the filter rack so that the filter is readily accessible.

Install the air handler with the door firmly screwed in place to make sure the cabinet remains square.

Provide at least 2 feet (0.75 metres) of service clearance in front of the access panel of the air handler. Zero clearance is acceptable on all other faces.

### **Ductwork**

#### General

Ductwork installed in unheated spaces such as attics must be installed between the insulation and the heated space. Provide at least R-12 of insulation above ducts. If cooling is required, the branch and trunk lines must be insulated and sealed with a vapour barrier prior to applying house insulation.

If a fresh air duct is required, make connection to return air plenum at least 6 feet upstream from filter. Insulate all fresh air ducts.

#### Supply Ductwork

Supply trunks may be square or round. SEAL all joints and seams with metal tape or sealing compound. Volume

dampers for each of the main supply trunks must be accessible for balancing. (Near the supply plenum is preferred)

Locate outlets at least 6 inches from outside walls or window coverings.

### Return Ductwork

Return air plenum should be the same cross sectional area as the air handler return air opening. In vertical installations, a conventional return air drop and elbow is acceptable. The return duct /drop must be acoustically lined for 6 feet nearest the air handler.

### ***Risk of Freezing***

Steps must be taken to prevent the hot water coil from freezing. Coils that have failed due to freezing and damage caused by frozen coils are not covered under warranty.

### HRV and Fresh air connections

Fresh air and HRV connections to ductwork can pose a risk of dumping cold air into ductwork during periods of stand-by or continuous run. Calculate mixed air stream temperatures and provide interlock controls to prevent freezing conditions.

### Evaporator coils

Evaporator cooling coils that are mounted above the hot water coil pose a risk to the hot water coil in the event that the compressor contactor on the condenser sticks in the on position. When the call for cooling is satisfied, the blower will stop running and allow cold air from the evaporator coil to fall on to the hot water coil.

### Attic and crawl spaces

Air handlers may be located in areas subject to freezing conditions. It is necessary to protect the hot water coil and condensate drain from freezing.

## **ELECTRICAL**

---

**Warning!** - Make sure unit is properly grounded. Locate air handler on a separate electric circuit, or use the same circuit as the water heater or boiler.

Air handler wiring diagrams are located on the blower or door for easy reference during installation and servicing. Nameplate data is located on the side of the unit.

All air handlers operate on 115VAC/1ph/60hz line voltage. All control circuits are 24 VAC. One leg of the 24 VAC is grounded to the chassis.

### ***Thermostat***

**eco-pac/eco-duct™** air handlers are compatible with most standard heat/cool, heat pump, “electric heat”, “gas heat”, set-back or electronic thermostat. Some electronic thermostats (primarily “power robbing” types) require the addition of a resistor between the W & C terminals and the Y & C terminals. This is usually covered in the thermostat instruction manual. A 1,000 ohm, 5 watt resistor on each of the W and Y terminals will

usually be enough to drain the current required to power the thermostat. Some thermostats will need 250 ohm, 10 watt resistors on each of the W and Y terminals. For two-stage thermostats, contact Ecologix.

### Heat Anticipator Setting

For optimum comfort the anticipator setting should be set to provide approximately 4 cycles per hour

Typical Heat Anticipator Setting	<b>0.25 amps</b>
----------------------------------	------------------

Thermostat wire from the thermostat is connected to screw terminals located inside the air handler. The thermostat should be connected as follows:

- R – power (24vac)
- W – heating
- Y– cooling (if present)
- G – continuous run fan

C -- ground

Connect the thermostat to the appropriate screw terminal according to the chart below.

### **Dehumidistat**

The dehumidistat must be 24VAC, open on humidity rise. Remove the jumper between DEHUM and R. Connect to DEHUM (right side) and R terminals.

### **Boiler**

The yellow wires labeled TT on the relay are dry contacts for connection to a boiler or external pump.

### ***A/C Condensing Unit***

Connect to Y and C on the screw terminal inside the air handler.

Note	T'stat Connection	EP30-EC EDHV-12 EDHV-18	EP45-EC EP60-EC EDHV-24 EDHV-30	EP65-EC EDHV-36 EDHV-42	EP75-EC EDHV-48 EDHV-60	EP100-EC EDHV-100
1	Y1 + XLC	--	1.5 Tons	1.5 Tons	--	2.0 Tons
2	Y2 + XLC	--	2.0 Tons	2.0 Tons	--	2.5 Tons
3	Y1+Y2+XLC					3.0 Tons
4	Y1	1 Ton	2.5 Tons	2.5 Tons	3.5 Tons	3.5 Tons
5	Y2	1.5 Tons	3 Tons	3 Tons	4 Tons	4 Tons
6	Y1 + Y2	2 Tons	3 Tons	3.5 Tons	5 Tons	5 Tons
7	W1	75%	75%	75%	75%	75%
8	W2	100%	100%	100%	100%	100%

#### Notes:

1. Connect AC contactor\* and Y from t'stat to Y1, jumper XLC wire to R or Y1
2. Connect AC contactor\* and Y from t'stat to Y2, jumper XLC wire to R or Y2
3. Connect AC contactor\* and Y from t'stat to Y2, add a jumper from Y1 to Y2, jumper XLC wire to R or Y2
4. Connect AC contactor\* and Y from t'stat to Y1
5. Connect AC contactor\* and Y from t'stat to Y2
6. Connect AC contactor\* and Y from t'stat to Y2, add a jumper from Y1 to Y2
7. Connect W from t'stat to W1, remove the jumper.  
Heating capacity and airflow = 75% of rated
8. Connect W from t'stat to W2, with jumper between W1 and W2.  
Heating capacity and airflow = rated airflow

\* Connect other AC contactor wire to C (ground).

## START-UP PROCEDURES

---

**Do not start the air handler or water heater until ALL air has been purged!**

1. Fill the boiler loop or water heater with water, but do not start it.
2. Purge all air from the boiler heating or domestic water system.
3. Purge all air from the space-heating loop by closing the isolation valve on the return leg of the loop and open the drain to purge air. Open the return leg isolation valve and then close the drain valve.
4. Start the boiler or water heater according to the manufacturer's instructions. Set the design water temperature and wait for the system to shut off. You can check that the water

heater is set properly by running hot water from a faucet into a glass. Using a thermometer measure the temperature of the water as soon as the water heater burner shuts off. If the set-point temperature is too low or is above 140F, reset the tank control, run water until the burner starts again and repeat the measurement.

5. Turn on the power to the air handler and set the room thermostat for heat to energize the fan and pump. If a gurgling sound is present, it should subside within one minute. If noise is still present after one minute, repeat step 3 to purge air as necessary.

6. Check pipes for heating to make sure there is flow.

## SERVICE AND MAINTENANCE

---

### Filter

The **Ecologix** air handler is provided with a high-efficiency, pleated filter. This filter should be inspected monthly and replaced as required. Replacement filters are available from Ecologix.

### Duct cleaning

If proper filter maintenance is adhered to, duct cleaning will not be required for the life of the equipment.

### Coils

Air conditioning and heating coils should not require cleaning if the filter maintenance schedule is adhered to. If a filter is damaged or collapses from plugging, dust may foul the coils. If this happens, replace the filter and carefully vacuum the heating coil. The fan may need to be removed to gain access to the face of the heating coil.

### Air conditioning coil

At the start of each cooling season, check the drain connection to the cooling coil to ensure it is free of debris. If a plugged air conditioning coil is suspected, call a service technician for testing and cleaning

### Fan and motor

Check fan for dust once a year. If dirty, vacuum to remove dust. Keeping the fan blades clean will reduce noise and improve the capacity and efficiency of the heating system

### Pump

The circulating pump is water lubricated and should require no regular maintenance. The system control may have an optional cycle timer to exercise the pump even during prolonged periods of no heat to avoid seizing from long idle periods.

# TROUBLESHOOTING

---

## ***Thermostat Call Error***

First, review “How It Works” on page 6 for normal operation. It is normal for the fan to change speeds in heating mode.

If there is a call for cooling and call for heating at the same time, the heating call will have priority **and** the air conditioning condenser (outdoor unit) will come on. Check the thermostat for correct wiring. Some electronic thermostats and power robbing thermostats apply a voltage to the W and/or Y and/or G terminal. With the thermostat off, the voltage at W, Y and G should be zero compared to ground (C). Excessive voltage will be interpreted as a call from the thermostat.

## ***Pump does not run***

In areas where hard water is present the pump may “stick” and fail to run. Often, closing the isolation valve on the return leg and opening the drain port so that water flows through the pump can free this. For Grundfos pumps, remove the screw-on cover from the face of the pump, and rotate the shaft one turn with a slotted screwdriver. If either method fails to free the pump, removal for cleaning or replacement is necessary. The daily pump exerciser will help prevent pump sticking.

## ***Pump is noisy at start-up***

Air is present in heating loop. If sound has not diminished within 1 minute, purge air in accordance with the *Start-Up*

procedures. If heat source is a water heater, check to make sure branch connections for heating loop are horizontal to prevent the collecting of air in the heating loop. See the drawing: Typical Plumbing Connections at the front of this manual.

## ***Water heater T&P is weeping***

A check valve or back-flow preventer may have been installed in the system. Some form of pressure relief may be required. Options are:

- Install expansion tank
- Install pressure relief valve; locate outlet over laundry tub or floor drain.
- Install combination toilet tank/pressure relief valve

## ***Insufficient or no heat***

- Plugged air filter or coil. Refer to *Maintenance* section for filter care and coil cleaning.
- Air in heating loop; purge system.
- Inlet and outlet connections to air handler backwards; reverse connections.
- Water heater supply tube (dip tube) is restricted or damaged; check and/or replace.
- Supply water temperature set too low or not calibrated properly; check water temperature. In the case of water heater; If the temperature has been set low because of homeowner preference, it may be necessary to

install an anti-scald valve to control the faucet temperature and raise the operating temperature of the water heater.

- Restrictions in heating loop; remove restrictions, check valve stuck, isolation valves too restrictive, left partially closed after purging or closed valve.
- Water heater supply temperature is unstable. Check water heater setting and temperature sensors for good contact on coil headers.

### ***Cold water at hot faucet***

When heat source is a water heater, the most probable cause is reverse flow through the heating loop from a stuck check valve; repair or replace valve.

### ***Fan runs for cooling but not heating***

- Room thermostat may be connected improperly. Refer to *Electrical* section or wiring schematic on door of air handler for proper installation.

### ***Heating during Standby Mode***

Probable cause is thermal siphoning. See check valve description for details; repair or replace check valve. Check elevation of air handler above water heater to see if motorized valve required for positive shut-off.

## eco-pac/eco-duct AIR HANDLER PARTS & ACCESSORY LIST

Part No.	Description	EP30-EC	EDHV-12	EDHV-18	EP45-EC	EP60-EC	EDHV-24	EDHV-30	EP65-EC	EDHV-36	EDHV-42	EP75-EC	EP100-EC	EDHV-48	EDHV-60	EDHV-100
UC12163	Hot Water Coil -- 12"x16"	S														
UC18203	Hot Water Coil – 20"x18"					S			S					S		
GUP15-42BUC5	Pump- Grundfos 1/2" c/w check	S														
GUP15-42BUC7	Pump-Grundfos 3/4" c/w check					S			S					S		
T006B	Pump – Taco 006 1/2" sweat	A														
T008B	Pump – Taco 008 3/4" sweat					A			A					A		
XPLC004	Vertical lift check valve 1/2"	A														
XPLC006	Vertical lift check valve 3/4"					A			A					A		
XELR024DPDT	Pump Relay 24VAC	S				S			S					S		
XELR01TIMER	Cycle Timer/Pump Exerciser	O				O			O					O		
XELT002	Transformer 24VAC, 40 VA	S				S			S					S		
XELT003	Transformer 24VAC, 25 VA	A				A			A					A		
XELD002	Door interlock switch	S				S			S					S		
XECM03	EC Blower motor -- -1/3 HP	S				S										
XECM04	EC Blower motor -- -1/2 HP					A			S							
XECM06	EC Blower motor -- -3/4 HP													S		
XBLF105T	Blower – 10x5T DD	S														
XBLF108	Blower – 10x8 DD					S			S							
XBLF128T	Blower – 12x8T DD													S		
XCA103	Washable Filter – specify size	14x18			22X22				22X22					22X22		
PF1418	Pleated filter - 14" x 18"	S														
PF2222	Pleated filter – 22" x 22"					S			S					S		
PME01	External pump module, 1/2" plumbing c/w check valve	O														
PME02	External pump module, 3/4" plumbing c/w check valve					O			O					O		
CPVA	Valve Assembly – 3/4" full port sweat ball valves plus hose bib for return	O				O			O					O		

S=Standard, A=Alternate, O=Option or Accessory





## PRODUCT WARRANTY

---

221 Holiday Inn Drive,  
Cambridge, ON, N3C 3T2

Phone: 519-658-4330  
Fax: 519-658-9384

www.ecologix.ca  
info@ecologix.ca

This product is warranted by Ecologix Heating Technologies Inc to be free from defects in materials and workmanship that affect product performance under normal use and maintenance within the applicable periods specified below. Replacements furnished will carry only the un-expired portion of the original warranty.

### Two-Year Parts

Ecologix Heating Technologies Inc will provide replacement parts for ANY part that fail within two years of purchase, subject to the **terms** below.

### Five-Year Parts

Ecologix Heating Technologies Inc will provide replacement parts for any heating coils, cooling coils, cabinetry and piping that fail within five years of purchase, subject to the **terms** below.

### Terms

- ❖ Reasonable proof of original purchase date must be provided in order to establish the effective date of the warranty, failing which, the effective date will be based on the date of manufacture plus thirty days.  
The warranty does not cover failure or damages caused by:
  - improper installation or operation
  - accident, abuse or alteration
  - operation of device at temperatures or pressures outside of the rated capacities
  - lime or scale deposits
  - corrosive operating environment
  - equipment moved from original installation location
- ❖ Replacements furnished under this warranty will be F.O.B. Ecologix Heating Technologies Inc product distribution points in the United States and Canada. They will be invoiced at regular prices. The account will be credited the full amount when the defective part is received by Ecologix, examined and approved as a valid warranty.
- ❖ Warranty applies to the original purchaser, but may be transferred to another owner provided the equipment is not moved from the original installation site.
- ❖ This warranty does not apply to labour, freight or any other cost associated with the service repair or operation of the product.
- ❖ Ecologix shall not be liable for any direct, special, incidental or consequential damages caused by the use, misuse, or inability to use this product.
- ❖ Ecologix is under no legal obligations to rectify, including but not limited to, lost profits, downtime, good will, damages to, or replacement of equipment and property
- ❖ Purchaser assumes all risk and liability of loss, damage or injury to purchaser and purchaser's property and to others and their property arising out of the use, misuse or inability to use this product.

