



90 Monarch Road
Guelph, Ontario, N1K 1S3

Phone: 855-658-4330
Fax: 855-658-9384

www.ecologix.ca
info@ecologix.ca

Installation Instructions

ECE-H
VTAC Units with DX Air Conditioning and
Hydronic Heat
R-410a

ECOLOGIX HEATING TECHNOLOGIES INC.
REV: 8/31/2021



90 Monarch Road
Guelph, Ontario, N1K 1S3

Phone: 855-658-4330
Fax: 855-658-9384

www.ecologix.ca
info@ecologix.ca

Contents

IMPORTANT NOTES FOR THE INSTALLER	3
EQUIPMENT ASSEMBLY DETAILS	4
ELECTRICAL WIRING DIAGRAM	5
ECE-H Wiring Diagram.....	5
PHYSICAL PROPERTIES	6
INTRODUCTION	8
PRODUCT DESCRIPTION	8
<i>Cabinet</i>	8
<i>Refrigerant Coils</i>	8
<i>Heating Coils</i>	8
<i>Circulation Pump</i>	8
<i>Check Valve</i>	8
<i>Circulation Pump</i>	9
<i>Fan and Motor</i>	9
<i>Compressor</i>	9
EQUIPMENT SELECTION AND SIZING	9
INSTALLATION	9
<i>Inspection</i>	10
<i>Location</i>	10
<i>Operating Environment</i>	10
<i>Mounting – Wall Sleeve</i>	10
<i>Ductwork</i>	11
<i>Risk of Freezing</i>	11
ELECTRICAL	11
<i>Low Voltage Control Wiring</i>	12
START-UP PROCEDURES	12
SERVICE AND MAINTENANCE	12
TROUBLESHOOTING	13
START UP INFORMATION AND TROUBLESHOOTING CHART	16
WARRANTY	17

IMPORTANT NOTES FOR THE INSTALLER

<input checked="" type="checkbox"/>	A Quick Check List
<input type="checkbox"/>	Is the wall sleeve installed square and caulked to the exterior wall?
<input type="checkbox"/>	Is the grille installed?
<input type="checkbox"/>	Is the base of the sleeve sloped to the outdoors?
<input type="checkbox"/>	Is the disconnect properly sized and installed according to local code?
<input type="checkbox"/>	Is there an installation manual for the homeowner?
<input type="checkbox"/>	Is the low voltage wire connected between the air handler and condenser?
<input type="checkbox"/>	Are the service panels closed?
<input type="checkbox"/>	Is the unit accessible? Are there clearances for service?
<input type="checkbox"/>	Has a filter been installed on the return air side of the unit?

EQUIPMENT ASSEMBLY DETAILS

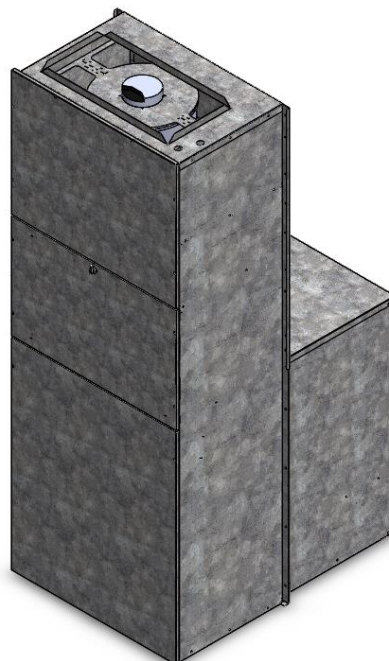
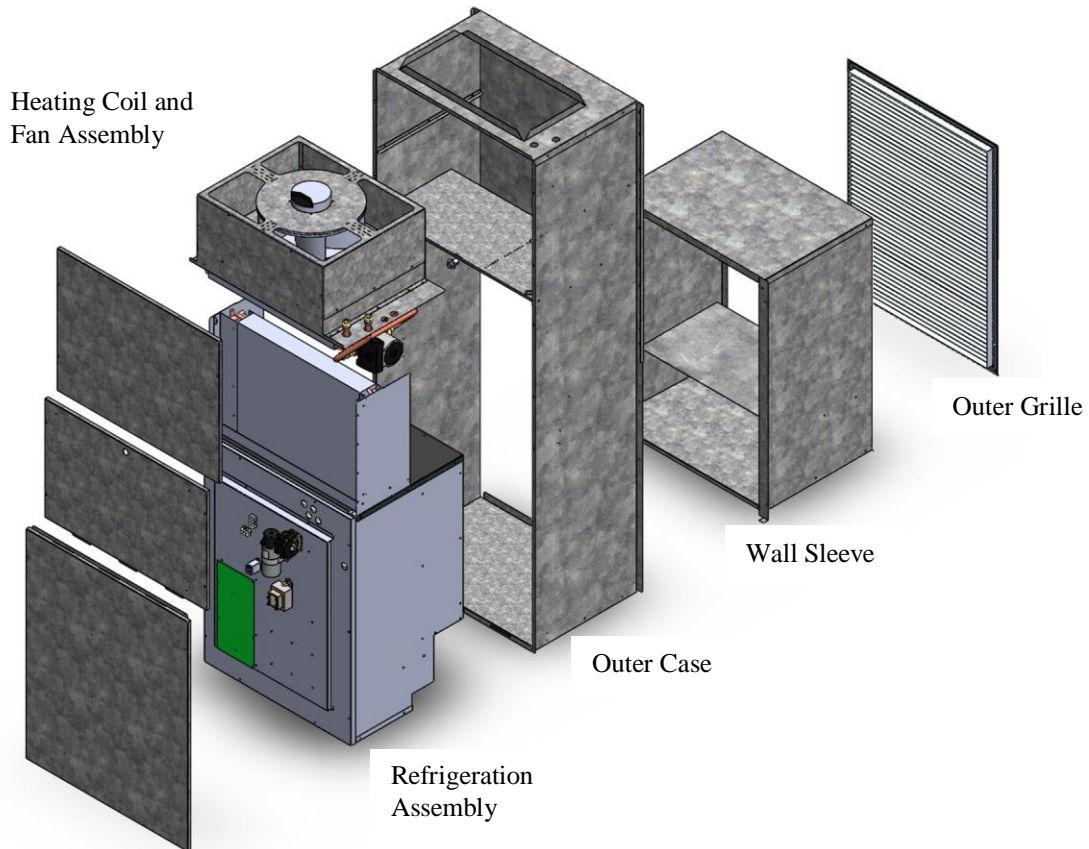

ELECTRICAL WIRING DIAGRAM

ECE-H Wiring Diagram

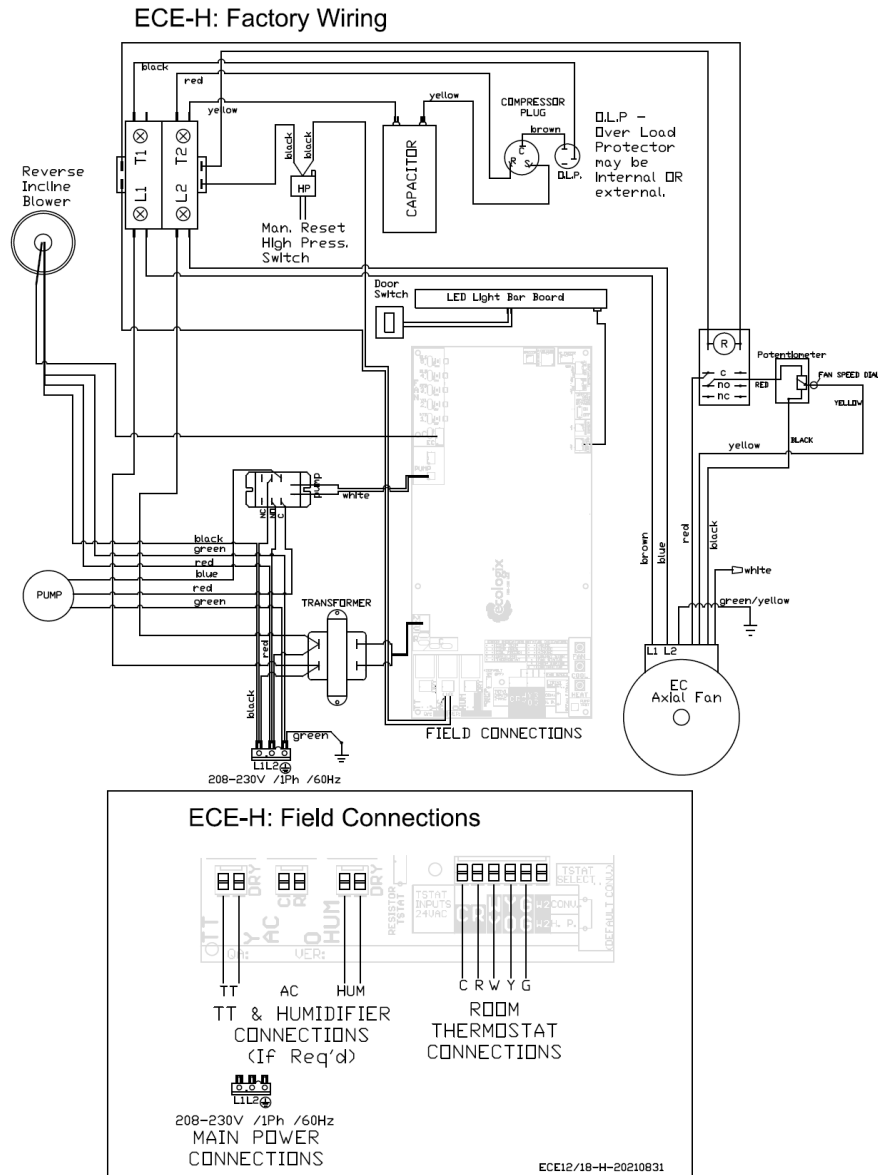

This diagram is provided as reference only. Wiring may differ depending on unit. Always refer to correct wiring diagram located on inside cover of electrical panel

Optional items that may be ordered separately or field installed:

- ICM220 solid state lock out
- Cold weather kit c/w/ fan control
- Low ambient lockout
- Crankcase heater

PHYSICAL PROPERTIES

Dimensions

Model	Inside Cabinet Dimensions (ins)			Wall Sleeve Dimensions (ins)		
	Width	Height	Depth	Width	Height	Wall Depth (Min-Max)
ECE09-H33	25	68	17	24.5	32	10", 14" 18"
ECE12-H33	25	68	17	24.5	32	10", 14" 18"
ECE18-H33	25	68	17	24.5	32	10", 14" 18"
ECE18-H40	25	68	17	24.5	32	10", 14" 18"
ECE24-H40	25	68	17	24.5	32	10", 14" 18"

Physical Properties

MODEL:	ECE09-H33	ECE12-H33	ECE18-H33	ECE18-H40	ECE24-H40
Supply Air (WxD) inches	12"x20"	12"x20"	12"x20"	12"x20"	12"x20"
Return Air (WxD) inches (Side)	12"x20"	12"x20"	12"x20"	12"x20"	12"x20"
Return Air (WxD) inches (Front)	14"x23"	14"x23"	14"x23"	14"x23"	14"x23"
Filter Rack Size (WxD) inches	16"x25"	16"x25"	16"x25"	16"x25"	16"x25"
Water inlet and outlet	1/2"	1/2"	1/2"	1/2"	1/2"
Coil size (length x width - rows)	13x20-2R	13x20-2R	13x20-2R	13x20-3R	13x20-3R
Shipping weight – pounds	160	168	180	182	188
Power (Volts/Phase/Hz)	230/1/60	230/1/60	230/1/60	230/1/60	230/1/60
Minimum Ampacity	7	8	11	11	24
Max over current (fuse size) Amps	15	15	20	20	30

PERFORMANCE Specifications

MODEL:	ECE09-H33	ECE12-H33	ECE18-H33	ECE18-H40	ECE24-H40
Heating Capacity (Btu/h) 100F	14,000	14,000	14,000	17,000	17,000
Heating Capacity (Btu/h) 110F	18,600	18,600	18,600	22,700	22,700
Heating Capacity (Btu/h) 120F	23,200	23,200	23,200	28,200	28,200
Heating Capacity (Btu/h) 130F	27,900	27,900	27,900	33,800	33,800
Heating Capacity (Btu/h) 140F	33,000	33,000	33,000	39,800	39,800
Heating Capacity (Btu/h) 160F	42,900	42,900	42,900	51,800	51,800
Heating Capacity (Btu/h) 180F	52,700	52,700	52,700	63,500	63,500
Cooling Capacity – High (Tons)	3/4	1.0	1.5	1.5	2.0
Continuous run speeds - cfm	240-400	240-400	240-400	240-400	240-400
Heating Air flow speeds - cfm	480	480	640	640	640
Cooling air flow speeds – cfm	320	480	640	640	800
Circulator Pump Flow(GPM)	2.8	2.8	2.8	3.5	3.5
Maximum Airflow (CFM)	640	640	640	800	800
Max. Ext. Static Pressure (in.wc)	1.0	1.0	1.0	1.0	1.0

1. Heating capacities are based on 70F return air, Med high fan speed. For medium low speed de-rate capacity by 20%. For low-speed de-rate capacity by 40%
2. Air handler can deliver the programmed airflow at any static pressure below the maximum external static pressure.
3. Fan speeds are torque limited to 30%,40% 60% 80% 100% which approximates air flows of 800, 640,480, 320, 240 cfm.
4. All fan speeds are recommended settings. Use temperature rise of temperature drop measurements as described in the installation instructions for setting fan speeds do not rely on this table. This is for initial setting and calculation purposes only.

INTRODUCTION

ECE-H VTAC units are complete packaged heating and cooling units that are installed through the wall and serviced from inside the dwelling. Their modular design ensures easy install and serviceability. They are ideally suited to high-rise buildings where exterior space and accessibility can be major issues.

For heating, the ECE-H comes with a built-in hydronic coil and pump designed for use in hydronic (boiler) systems, hydronic heat pump systems, or

combination space and water heating systems (Combo System). Combo heating systems use the home's water heater to provide both the space heating and domestic hot water, eliminating the need for a furnace.

The ECE-H contains a complete refrigeration system for cooling, eliminating the need for additional line-sets, brazing inside of the suite, and adjusting the system refrigerant charge.

PRODUCT DESCRIPTION

Cabinet

All cabinets have a tough, durable low maintenance G90 galvanized finish.

Cabinet dimensions are compact to provide maximum installation flexibility. Refer to product specifications and installation requirements for more details.

A variety of grilles are available to compliment the building exterior.

The ECE-H unit consists of an Outer Cabinet, Heating Coil and Fan Assembly, and Refrigeration Assembly. The Outer Cabinet is designed as a shell that the ductwork connects to and the Heating Coil and Fan Assembly and Refrigeration Assembly slide into.

Refrigerant Coils

All coils and internal piping conform to ASTM B68 or ASTM B88 standards.

High-density aluminum fins provide maximum heat transfer for small coil surface.

Heating Coils

All heating coils are potable water grade copper suitable for use in plumbing systems. No lead solder is used in any component construction. All coils and internal piping conform to ASTM B68 or ASTM B88 standards. High-density aluminum fins provide maximum heat transfer for small coil surface.

Circulation Pump

The circulation pump is matched for maximum performance. The ECE-H comes with internally mounted pump for ease of installation.

Check Valve

The heating coils come with built-in spring-loaded check valves located in the outlet of the internal pump. Check valves

protect against back-flow of water to avoid short circuiting around the water heater during domestic use.

Circulation Pump

The air handler is equipped with a pump exerciser that brings on the pump for 90 seconds every 24 hours to flush any water through the system at least once a day. A test button on the control allows for easy verification that the pump exerciser is operating correctly.

Fan and Motor

All fans are wide body dynamically balanced for extra quiet operation.

Compressor

Small compressors are available to closely match room loads in small or energy-efficient spaces.

EQUIPMENT SELECTION AND SIZING

Proper sizing of system components is crucial for proper operation.

Steps for sizing and selection:

- 1) Obtain room by room heat gain
- 2) Select a condenser equal to 80%-120% of the total heat gain.
- 3) Determine inlet water temperature (for heating).
- 4) Select ECE-H unit with heating capacity between 100% and 140% of the heat loss. *(110% to 140% for combo systems @ 130F water temperature)*

Note: over-sizing of cooling equipment results in inefficiency, short cycles and poor humidity control.

When using a boiler system, select a boiler with an output that meets or exceeds the heat loss of the space being heated. If the boiler is serving additional loads, size the boiler to meet the total combined load.

For combo heating systems, use an approved sizing method such as the Unified Combo Guidelines published by HRAI.

INSTALLATION

WARNING !

Installation should only be performed by qualified personnel. In addition to this manual, all local codes shall be followed.

Improper installation may void all warranties.

Detailed instructions are shipped with all accessory items and should be followed.

Inspection

Carefully uncrate the equipment. Ensure that the rated voltage and capacity on the nameplate matches the requirement for the installation. If there is damage to the machine, a claim must be made to your carrier immediately. Shipping damage is the responsibility of the purchaser to file all necessary documents with their carrier. Remove any shipping materials.

Location

Consideration must be given to location. The machine must be mounted in an area with adequate clearance and access for servicing. Consideration must also be given to noise and vibration that is normal for operation of this unit. Additional isolation may be required in occupant sensitive locations.

If the machine is installed in a closet or behind a sealed panel, there must be adequate provision for service (2 ft./60cm).

For installation in a concrete, brick or block wall; the wall sleeve must be used. For installation in a wood frame wall, including face brick with proper lintel, the wall sleeve can be omitted. The entire base of the condenser unit must be supported. The cabinet shall be caulked in place at the exterior.

Allow at least six feet clearance in front of the grille outdoors for proper air circulation and heat dissipation.

Operating Environment

Do not install in a corrosive environment containing chlorine, fluorine, solvents or other corrosive chemicals. Do not install in any atmosphere containing explosive or flammable vapours.

Internal controls should not be exposed to temperatures above 105°F/41°C and should not operate in a condensing environment.

If the cooling unit is to be operated at temperatures below 50°F/10°C, a cold weather kit must be installed.

Mounting – Wall Sleeve

Assemble and install the wall sleeve according to the instruction sheet provided with the wall sleeve. The wall sleeve should be square and installed flush to the outdoor finished wall surface. The wall sleeve can be fastened through the inside face of the sides to the building framing with #10 pan head screws. When doing so, ensure that the screws are at least 8-1/4" back from the inside flange of the wall sleeve to avoid interference with the Refrigerant Assembly when the ECE is installed. The wall sleeve inside flanges can also be used to fasten to the wall framing if the depths match. Do not screw through the base of the wall sleeve. The base of the wall sleeve has a built-in slope to provide adequate drainage. There is no need to slope the condenser outward for drainage. The entire base of the wall sleeve should be properly supported. Provide flashing and seal outside edge of cabinet to wall to ensure a watertight finish. Make sure drip edge at bottom extends beyond wall finish.

Remember to rough-in power wire and control wire before completing interior finishes. The electrical wires can be located on the left or right side of the unit.

The interior may be finished tight to the wall sleeve and/or the ECE outer cabinet. The outer cabinet is designed to match up with the inside flanges of the wall sleeve. The condenser fan portion of the refrigerant assembly protrudes into the wall sleeve.

Ductwork

Supply trunks may be square or round. SEAL all joints and seams with metal tape or sealing compound. Locate outlets at least 6 inches from outside walls or window coverings.

Ductwork installed in unheated space, such as attics, must be installed between the insulation and the heated space. Provide at least R-12 of insulation above ducts. If cooling is required, the branch and trunk lines must be insulated and sealed with a vapour barrier prior to applying house insulation.

Risk of Freezing

Steps must be taken to prevent the hot water coil from freezing. Coils that have failed due to freezing and damage caused by frozen coils are not covered under warranty.

Make sure that the indoor fan speed is correctly selected for the cooling load installed.

HRV and Fresh Air Connections

If a fresh air duct is required, make connection to return air plenum at least 18 inches from filter. Insulate all fresh air ducts.

Fresh air and HRV connections to ductwork can pose a risk of dumping cold air into ductwork during periods of stand-by or continuous run. Calculate mixed air stream temperatures and provide interlock controls to prevent freezing conditions.

If an HRV is to be attached to the return ductwork, the HRV must be interlocked to the air handler controls to ensure the air handler fan is forced to run when the HRV is in operation. This interlock is required for both summer and winter operation.

ELECTRICAL

WARNING !

Make sure unit is properly grounded. Locate condensing unit on a separate electric circuit. Provide a line of site disconnect according to local code requirements.

The wiring diagram is located on the service door. A copy is provided in this document for reference only. Nameplate data is located on the side of the unit. Ampacity is also shown in the

specification table. If there is a difference in ampacity and circuit size between the rating plate and this document, the rating plate shall be followed.

All ECE units operate on 230VAC/1ph/60hz line voltage. All control circuits are 24 VAC.

Use copper conductors only. Connect power wires to terminal lugs in the electrical section. Protect and seal wires where they enter the condenser cabinet.

Low Voltage Control Wiring

Connect low voltage control wire (i.e. thermostat wires) to the control board in the electrical section. Protect and seal wires where they enter the condenser cabinet.

START-UP PROCEDURES

1. Verify power is connected to the contactor in the electrical panel.

2. Verify that the thermostat is installed. Verify that the thermostat wiring is done between the thermostat and control board.

4. Install all service panels of the ECE unit. Ensure that the filter ins installed in the air handler section.

5. Turn on the power to the ECE unit. Set the room thermostat for heating or cooling to test the systems functionality. In heating, the unit should bring on the circulating pump and indoor fan. In cooling, the unit should bring on the indoor fan, outdoor fan, and compressor. Note: some thermostats and air handlers have a five minute lock-out delay.

SERVICE AND MAINTENANCE

WARNING !

Service should only be provided by qualified personnel. Disconnect electrical supply before opening service panels.

Wiring

Examine wires for signs of pinching, fraying or charring. Replace as necessary.

Condenser Coil

Examine the condenser coil for lint, debris or damage. Wash or vacuum if necessary.

Fan and motor

Check fan for dust once a year. The fan is accessible and removable through the top panel. If dirty, vacuum to remove dust. Keeping the fan blades clean will reduce noise and improve the capacity and efficiency of the cooling system.

Filter

All ECE-H units require a filter on the return air to the unit. This filter should be inspected monthly and replaced as required. Replacement filters are

available from Ecologix or can be sourced from your local hardware store.

coil to ensure it is free of debris. If a plugged air conditioning coil is suspected, call a service technician for testing and cleaning.

Evapourator Coil

At the start of each cooling season, check the drain connection to the cooling

TROUBLESHOOTING

WARNING !

Service should only be performed by qualified personnel. Take proper care to disconnect voltage supply. Use caution when working near charged capacitors.

Symptom	Cause	Check
Fan and compressor will not operate	<ol style="list-style-type: none"> 1. Power off 2. Improperly wired 3. Loose connections 4. 24vac supply 5. Thermostat 6. Firestat/Freezestat 	<ol style="list-style-type: none"> 1. Check main fuse/circuit breaker and remote disconnect. Measure power and control voltages at condenser. 2. Check power and control wiring. Refer to wiring diagram. 3. Check wiring. 4. Measure voltage and check ampacity (should be at least 40VA, replace transformer if faulty or under-sized. 5. Thermostat or air handler may have a delay of up to five minutes. Check thermostat settings. Disconnect thermostat and apply 24vac directly from air handler. If it operates, fault is at thermostat or a.h. control. 6. Determine cause of trip. Repair/reset/replace Firestat/freezestat if necessary.
Fan operates, compressor does not	Safety lock-out	<ol style="list-style-type: none"> 1. Reset thermostat 2. Check manual reset high pressure switch.
Compressor hums, won't start	<ol style="list-style-type: none"> 1. Low voltage or wrong voltage 2. Capacitor problem 	<ol style="list-style-type: none"> 1. Check wiring and voltage at unit, check wire size, check for loose wires. 2. Test compressor capacitor, replace if necessary

<p>Fan starts but cuts out</p>	<ol style="list-style-type: none"> 1. Incorrect or low voltage 2. Capacitor problem 3. Doesn't turn freely 4. Seized 5. High internal amperage 	<ol style="list-style-type: none"> 1. Check wiring and voltage at unit, check wire size, check for loose wires. 2. Test fan capacitor, replace if necessary 3. Oil motor, check bearings, replace fan motor if necessary. 4. Replace fan motor 5. Change to lower fan speed
<p>High suction pressure</p>	<ol style="list-style-type: none"> 1. Excessive evap. Air 2. Excessive load 3. High latent heat 	<ol style="list-style-type: none"> 1. Confirm correct amount of evap. Air, adjust air handler air flow. 2. Estimate space cooling load and compare to unit capacity. Replace with larger cooling unit if necessary. 3. Estimate space cooling latent load and compare to unit latent capacity.
<p>High discharge pressure</p>	<ol style="list-style-type: none"> 1. Insufficient air over condenser. 2. Plugged or restricted air over condenser coil 	<ol style="list-style-type: none"> 1. Adjust condenser fan speed. 2. Wash or vacuum condenser coil.
<p>Thermostat call error</p>	<ol style="list-style-type: none"> 1. Thermostat issue (simultaneous heat & cool call) 2. Alarm condition 	<ol style="list-style-type: none"> 1. Check status lights on control board to see if the call is being seen by the control. 2. Check error lights on board to see if there is a thermostat error.
<p>Pump does not run</p>	<ol style="list-style-type: none"> 1. Hard water causing pump to "stick". 2. Failed pump relay. 	<ol style="list-style-type: none"> 1. Close isolation valve on return leg and open drain port to force water flow through pump to free it. If this doesn't fix issue, removal for cleaning or replacement is necessary. 2. Check to make sure pump is relay is functioning properly.
<p>Insufficient or No Heat</p>	<ol style="list-style-type: none"> 1. Plugged air filter or coil. 2. Air in heating loop. 3. Inlet and outlet connections to air handler backwards. 4. Water heater supply tube (dip tube) is restricted or 	<ol style="list-style-type: none"> 1. Refer to Maintenance section for filter and care and coil cleaning. 2. Purge system 3. Reverse connections. 4. Check and/or replace. 5. Check water temperature. 6. Check if valve is stuck, isolation valves could be too restrictive or left partially closed after purging.

	<p>damaged.</p> <p>5. Supply water temperature set too low or not calibrated properly.</p> <p>6. Restriction in heating loop.</p>	Possibly closed valve.
Cold water at hot faucet	<p>1. If water heater, the most probable cause is reverse flow through the heating loop from a stuck check valve.</p>	<p>1. Repair or replace valve.</p>
Fan runs for cooling but not heating	<p>1. Room thermostat may be connected improperly.</p>	<p>1. Refer to wiring diagram for proper installation</p>
Heating during standby mode	<p>1. Probable cause is thermal siphoning.</p>	<p>1. Make sure piping elevation instructions shown in piping drawings have been followed.</p> <p>2. Repair or replace check valve.</p> <p>3. Check elevation of air handler above water heater to see if motorized valve required for positive shut-off.</p>

If you require diagnostic assistance, complete the Troubleshooting chart and send to your distributor.

START UP INFORMATION AND TROUBLESHOOTING CHART

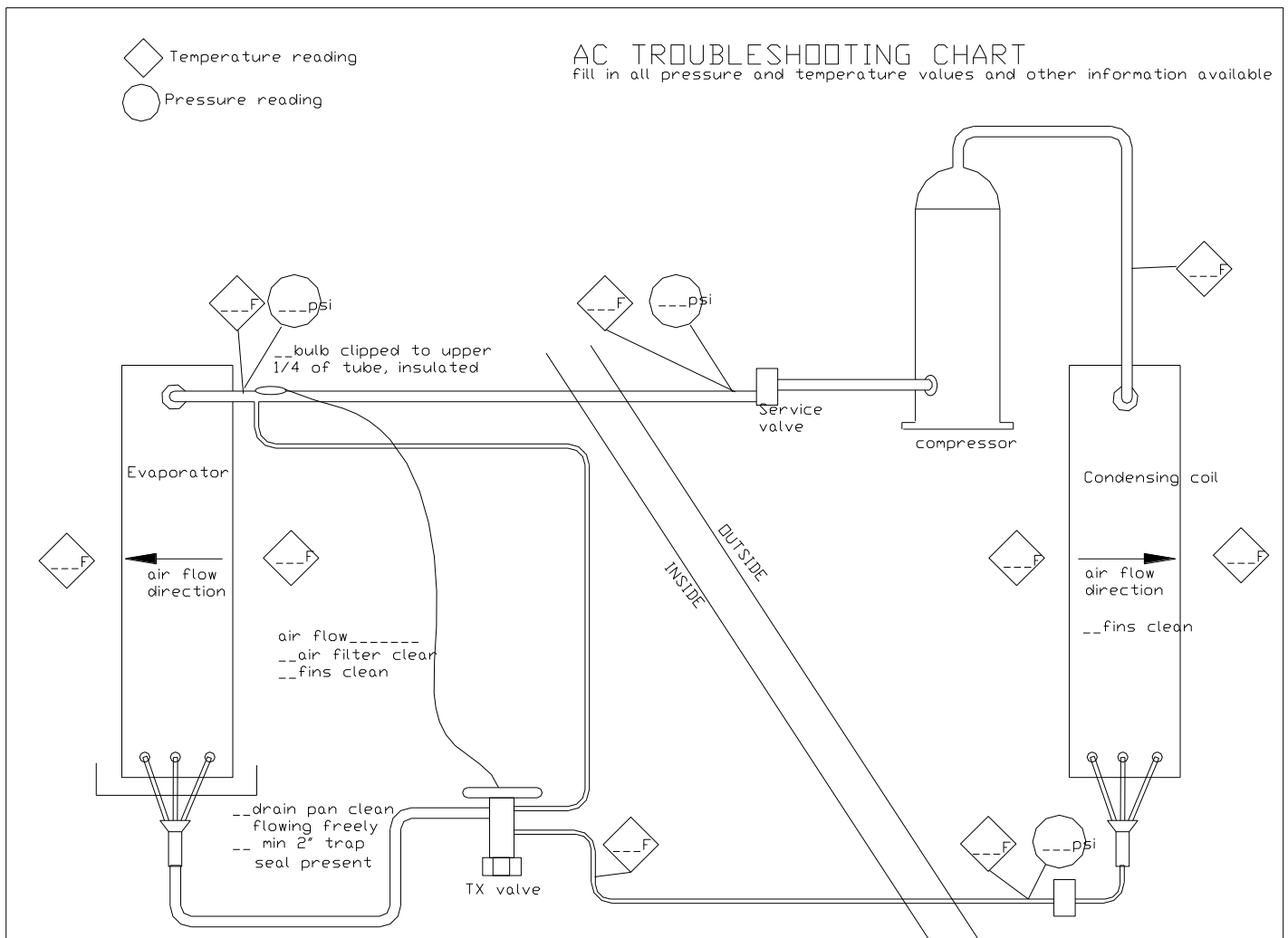

WARRANTY

This product is warranted by Ecologix Heating Technologies Inc to be free from defects in materials and workmanship that affect product performance under normal use and maintenance within the applicable periods specified below. Replacements furnished will carry only the un-expired portion of the original warranty.

Two-Year Parts

Ecologix Heating Technologies Inc will provide replacement parts for ANY part that fail within two years of purchase, subject to the **terms** below.

Five-Year Parts

Ecologix Heating Technologies Inc will provide replacement parts for compressor, refrigerant coil, water coil, cabinetry and piping that fail within five years of purchase, subject to the **terms** below.

Terms

- ❖ Reasonable proof of original purchase date must be provided in order to establish the effective date of the warranty, failing which, the effective date will be based on the date of manufacture plus thirty days.
The warranty does not cover failure or damages caused by:
 - improper installation or operation
 - accident, abuse or alteration
 - operation of device at temperatures or pressures outside of the rated capacities
 - corrosive operating environment
 - equipment moved from original installation location
- ❖ Replacements furnished under this warranty will be F.O.B. Ecologix Heating Technologies Inc product distribution points in the United States and Canada. They will be invoiced at regular prices. The account will be credited the full amount when the defective part is received by Ecologix, examined and approved as a valid warranty.
- ❖ Warranty applies to the original purchaser, but may be transferred to another owner provided the equipment is not moved from the original installation site.
- ❖ This warranty does not apply to labour, freight or any other cost associated with the service repair or operation of the product.
- ❖ Ecologix shall not be liable for any direct, special, incidental or consequential damages caused by the use, misuse, or inability to use this product.
- ❖ Ecologix is under no legal obligations to rectify, including but not limited to, lost profits, downtime, good will, damages to, or replacement of equipment and property
- ❖ Purchaser assumes all risk and liability of loss, damage or injury to purchaser and purchaser's property and to others and their property arising out of the use, misuse or inability to use this product.