

## ECN series Vertical Through Wall Units DX Air Conditioning with Hydronic Heating

- Insulated for sound attenuation
- Installed and serviced from the indoors
- 208 / 230V single phase
- G90 Galvanized for long rust-free life
- AC has Axial EC variable speed fan motor with field adjustable speed settings.
- Indoor fan is 5 speed EC motor with independent rotary dial speed controls for Heating, Cooling and Continuous Fan speeds.
- Wall sleeve is adjustable to allow for different wall thicknesses
- Indoor section Narrow construction to minimize box out width in living space.
- Optional Internal condensate pump is available where no floor drain is available in closet.
- Overflow control with audible alarm available for condensate drain pans or in bottom of unit to alarm and shut down unit in case of flooding.

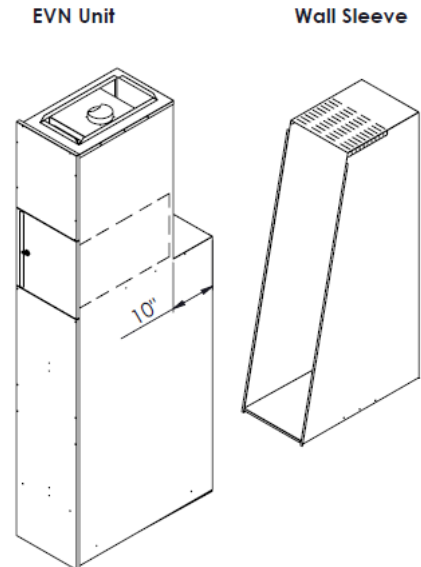

### Dimensions

Model	Inside Cabinet Dimensions (ins)			Wall Sleeve Dimensions (ins)		
	Width	Height	Depth	Width	Height	Wall Depth (Min-Max)
ECN09-H33	15.5	93	25	14.5	58.75	10-18
ECN12-H33	15.5	93	25	14.5	58.75	10-18
ECN18-H33	15.5	93	25	14.5	58.75	10-18
ECN18-H40	15.5	93	25	14.5	58.75	10-18
ECN24-H40	15.5	93	25	14.5	58.75	10-18

## Physical Properties

MODEL:	ECN09-H33	ECN12-H33	ECN18-H33	ECN18-H40	ECN24-H40
Supply Air (WxD) inches	12"x20"	12"x20"	12"x20"	12"x20"	12"x20"
Return Air (WxD) inches (Side)	14"x23"	14"x23"	14"x23"	14"x23"	14"x23"
Return Air (WxD) inches (Front)	NA	NA	NA	NA	NA
Internal Filter Size (WxD) inches	16"x25"	16"x25"	16"x25"	16"x25"	16"x25"
Water inlet and outlet	1/2"	1/2"	1/2"	3/4"	3/4"
Coil size (length x width - rows)	13x20-2R	13x20-2R	22x20-2R	22x20-3R	22x20-3R
Shipping weight – pounds	160	168	180	182	188
Power (Volts/Phase/Hz)	230/1/60	230/1/60	230/1/60	230/1/60	230/1/60
Minimum Ampacity	7	8	11	24	24
Max over current (fuse size) Amps	15	15	20	20	30

## PERFORMANCE Specifications

MODEL:	ECN09-H33	ECN12-H33	ECN18-H33	ECN18-H40	ECN24-H40
Heating Capacity (Btu/h) 100F	14,000	14,000	14,000	17,000	17,000
Heating Capacity (Btu/h) 110F	18,600	18,600	18,600	22,700	22,700
Heating Capacity (Btu/h) 120F	23,200	23,200	23,200	28,200	28,200
Heating Capacity (Btu/h) 130F	27,900	27,900	27,900	33,800	33,800
Heating Capacity (Btu/h) 140F	33,000	33,000	33,000	39,800	39,800
Heating Capacity (Btu/h) 160F	42,900	42,900	42,900	51,800	51,800
Heating Capacity (Btu/h) 180F	52,700	52,700	52,700	63,500	63,500
Cooling Capacity – High (Tons)	3/4	1.0	1.5	1.5	2.0
Continuous run speeds - cfm	240-400	240-400	240-400	240-400	240-400
Heating Air flow speeds - cfm	480	480	480	640	640
Cooling air flow speeds – cfm	320	480	640	640	800
Circulator Pump Flow (GPM)	2.8	2.8	2.8	3.5	3.5
Maximum Airflow (CFM)	640	640	640	800	800
Max. Ext. Static Pressure (in.wc)	1.0	1.0	1.0	1.0	1.0

1. Heating capacities are based on 70F return air, Med high fan speed. For medium low speed de-rate capacity by 20%. For low-speed de-rate capacity by 40%
2. Air handler can deliver the programmed airflow at any static pressure below the maximum external static pressure.
3. Fan speeds are torque limited to 30%,40% 60% 80% 100% which approximates air flows of 800, 640,480, 320, 240 cfm.
4. All fan speeds are recommended settings. Use temperature rise of temperature drop measurements as described in the installation instructions for setting fan speeds do not rely on this table. This is for initial setting and calculation purposes only.